

THERMOSTATIC MIXING VALVE

PREMIUM SERIES VTS520, VTS550

The ESBE thermostatic mixing valves series VTS520 and VTS550 offer high flow capacity and high functionality for domestic hot water distribution connected to solar heating systems with high water temperatures.

OPERATION

Series VTS520/VTS550 are the number one choice for domestic hot water distribution connected to solar heating systems, where the high water temperatures require extra durable components. The VTS520/VTS550 offers an in-line scald safe* function and are suitable for use where further temperature control devices have been installed at the water taps. These series of valves are also suitable for domestic hot water installations equipped with HWC (hot water circulation).

FUNCTION

VTS520 has asymmetrical flow pattern, VTS550 has symmetrical flow pattern. Scald safe*.

VERSIONS

The product range includes a wide choice of valves delivered with adapter fitting kits, each including three adapter fittings and two check valves, which facilitate easy installation and maintenance.

Supplied with a top cover, unless otherwise stated.

*) Scald safe means that in the case of a cold water failure, the hot water supply shuts off automatically.

MEDIA

These valves can handle the following types of media:

- Fresh water / Potable water
- Closed systems
- Water with antifreeze additive (glycol ≤ 50% mixture)



VTS520
External thread

With adapters,
external thread



VTS550
External thread

With adapters,
external thread

VALVES ARE DESIGNED FOR

Series	Temperature range		Application
	45 - 65°C	50 - 75°C	
VTS520	●	●	Potable water, in line
VTS550	●	●	
VTS520			Potable water, point of use
VTS550			
VTS520	●	●	Solar heating
VTS550	●	●	
VTS520			Cooling
VTS550			
VTS520			Floor heating
VTS550			
VTS520	○	○	Radiator heating
VTS550	○	○	

● recommended ○ secondary alternative

TECHNICAL DATA

Pressure class: _____ PN 10
 Working pressure: _____ 1,0 MPa (10 bar)
 Differential pressure: _____ Mixing, max. 0,3 MPa (3 bar)
 Media temperature: _____ continuously max. 110°C
 _____ temporarily max. 120°C
 Temperature stability: _____ ±4°C*
 Connection: _____ External thread (G), ISO 228/1
 _____ External thread (R), EN 10226-1

* Valid at unchanged hot/cold water pressure, minimum flow rate 9 l/min. Minimum temperature difference between hot water inlet and mixed water outlet 10°C.

Material

Valve housing and other metal parts with fluid contact:
 _____ Dezincification resistant brass, DZR

PED 2014/68/EU, article 4.3 / SI 2016 No. 1105 (UK)

Pressure Equipment in conformity with PED 2014/68/EU, article 4.3 and Pressure Equipment (Safety) Regulations 2016, (sound engineering practice). According to the directive/regulation the equipment shall not carry any CE or UKCA mark.

THERMOSTATIC MIXING VALVE

PREMIUM SERIES VTS520, VTS550

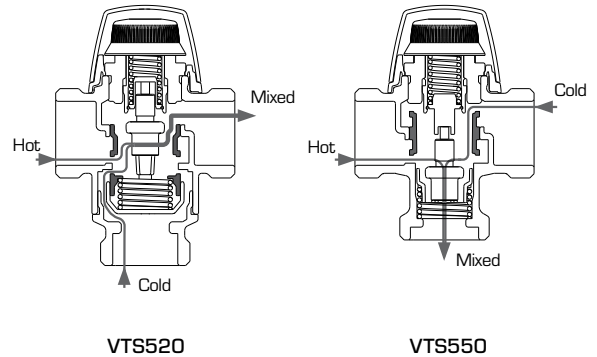
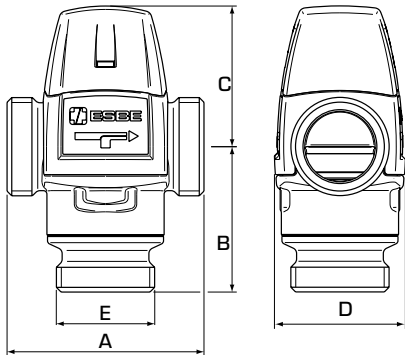

► SERIES VTS522, EXTERNAL THREAD

Art. No.	Reference	Temp. range	Kvs *	Connection E	Dimension				Note	Weight [kg]
					A	B	C	D		
31720100	VTS522	45 - 65°C	3,2	G 1"	84	62	60	56		0,86
31720300			3,5	G 1¼"						0,95
31720200	VTS522	50 - 75°C	3,2	G 1"	84	62	60	56		0,86
31720400			3,5	G 1¼"						0,95

▼ SERIES VTS552, EXTERNAL THREAD

Art. No.	Reference	Temp. range	Kvs *	Connection E	Dimension				Note	Weight [kg]
					A	B	C	D		
31740100	VTS552	45 - 65°C	3,2	G 1"	84	50	60	56		0,78
31740300			3,5	G 1¼"						0,87
31740200	VTS552	50 - 75°C	3,2	G 1"	84	50	60	56		0,78
31740400			3,5	G 1¼"						0,87

* Kvs-value in m³/h at a pressure drop of 1 bar.

INSTALLATION EXAMPLES

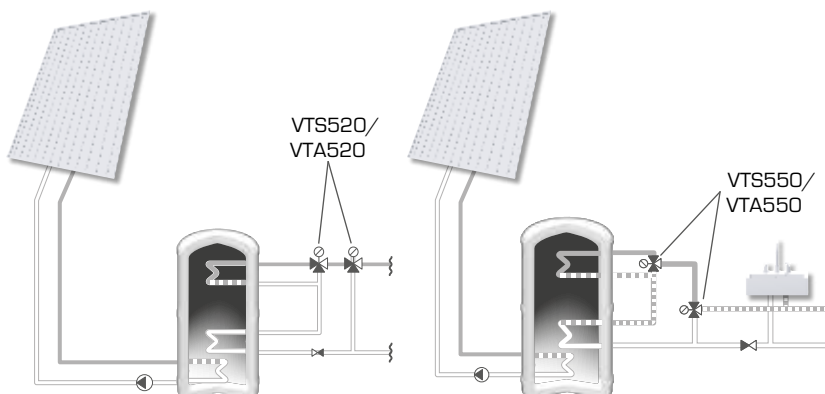

The shown applications are only examples of product use!
Before using the product in any application, the regional and national regulations need to be checked.

THERMOSTATIC MIXING VALVE

PREMIUM SERIES VTS520, VTS550

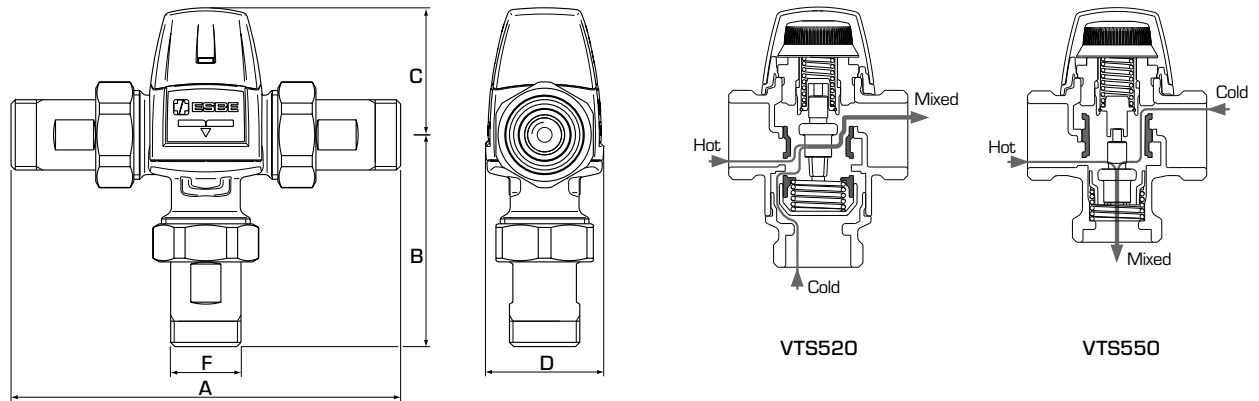

➤ SERIES VTS522, WITH ADAPTERS

Art. No.	Reference	Temp. range	Kvs *	Connection F	Dimension				Note	Weight [kg]
					A	B	C	D		
31720500	VTS522	45 - 65°C	3,0	R ¾"	154	97	60	56	1)	1,22

➤ SERIES VTS552, WITH ADAPTERS

Art. No.	Reference	Temp. range	Kvs *	Connection F	Dimension				Note	Weight [kg]
					A	B	C	D		
31740500	VTS552	45 - 65°C	3,0	R ¾"	154	85	60	56		1,14
31740700	VTS552		3,4	R 1"						1,51
31740600	VTS552	50 - 75°C	3,0	R ¾"	154	85	60	56		1,14

* Kvs-value in m³/h at a pressure drop of 1 bar.

Note 1) Two check valves for both hot and cold water are included

THERMOSTATIC MIXING VALVE

PREMIUM SERIES VTS520, VTS550

CAPACITY DIAGRAM

