

ROOM THERMOSTATS

ROOM THERMOSTAT SERIES TMA110

ESBE thermostat Series TMA110 consists of range of electro-mechanical room thermostats with gas filled bellow for use in heating applications.



TMA115



TMA116

APPLICATION

The ESBE series TMA110 is a range of ON/OFF electro-mechanical room thermostats for use in heating applications. The thermostats can be connected to 2-point or spring return actuator, a circulation pump or directly to a boiler.

VERSIONS

The series consist of 2 different versions:

- TMA115 is a thermostat for use in heating application. The regulating temperature range is between 8°C and 30°C and is set by the knob. A pin stop system can limit the set-point range. The contact rating is 16(2,5)A@250V AC.
- TMA116 is a thermostat for use in heating application with an ON/OFF switch and light indication. The regulating temperature range is between 8°C and 30°C and is set by the knob. A pin stop system can limit the set-point range. The light is on when the relay is active and must be powered with 230V AC. The contact rating is 10(1,5)A@250V AC.

TECHNICAL DATA

Ambient temperature: _____ max. 40°C
 _____ min. 0°C
 Ambient humidity: _____ 20...80% RH non-condensating
 Setting range: _____ see table
 Sensor type: _____ Gas filled bellow
 Differential/ hysteresis: _____ <1°K
 ErP Temperature controls class: _____ I
 Energy efficiency contribution: _____ 1%
 Enclosure rating: _____ IP30
 Contact rating – TMA115: _____ 16(2,5)A @ 250V AC
 TMA116: _____ 10(1,5)A @ 250V AC
 Protection class: _____ II

Material
 Housing: _____ ABS + PC self-extinguishing VO

Conformities and certificates:

CE LVD 2014/35/EU
 EMC 2014/30/EU
 RoHS3 2015/863/EU



SUITABLE ESBE ACTUATORS

Series	Control signal	ARA600	90	ARC300	ARD100	ARD200	ALG400	VZC/VZD	MBA100	ZRS100
TMA115, TMA116	2-point	ARA6x5, ARA6x6, ARA6x7, ARA6x8	M97, M98	ARC361, ARC363	ARD155, ARD157	ARD255, ARD257	ALG434, ALG436	•	•	•

ROOM THERMOSTAT SERIES TMA110

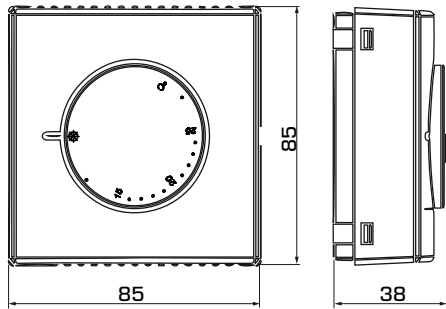

TMA115

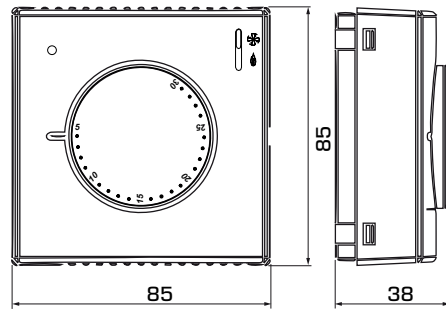

TMA116

SERIES TMA110

Art. No.	Reference	Application	Voltage	Contact rating	Setting range	Weight [kg]	Note
18000500	TMA115	Heating	-	16(2,5)A@250V AC	5-30°C	0,11	
18000600	TMA116		-	10(1,5)A@250V AC		0,12	ON/OFF switch

ROOM THERMOSTAT SERIES TMA110

WIRING

The wirings are typical examples of application; for further information, please check User instruction for all possibilities.

TMA115

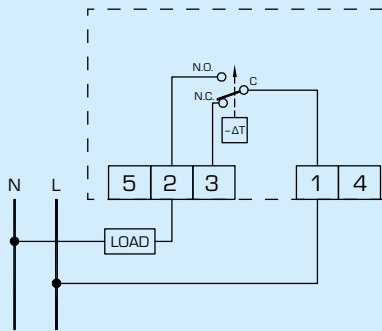

TMA116

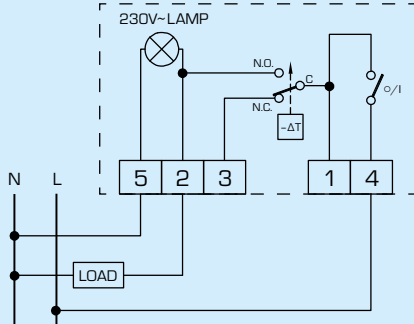

ELECTRICAL CONNECTION TO ESBE ACTUATORS

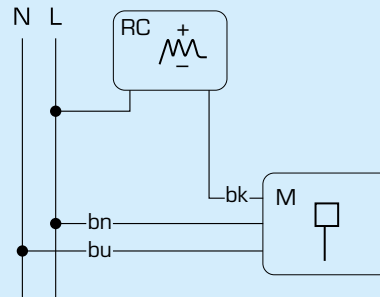

Series ARA600, 90, ARC300, VZC/VZD, MBA100

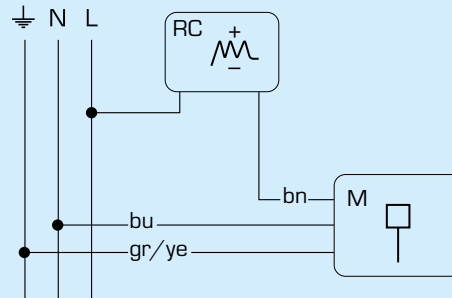

Series ZRS100

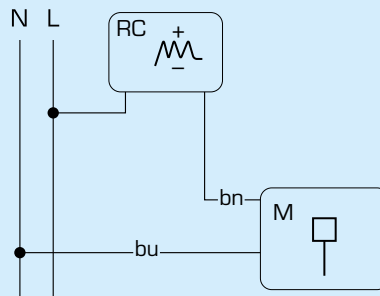

Series ARD100, ARD200, ALG400