

THERMOSTATIC CONTROL UNITS

THERMOSTATIC FLOW LIMITATION VALVE SERIES VTF320

Thermostatic flow limitation valves series VTF300 are valves preventing exceeding temperatures in potable hot water circulation systems.



OPERATION

The Series VTF320 are thermostatic 2-way flow limitation valves designed for potable hot water circulations systems in order to prevent energy losses and legionella growth in these applications.

FUNCTION

The Series VTF320 secures the correct temperature in the PHW-C pipes preventing the growth of legionella and reduces energy losses. The VTF320 comes with fixed temperature of 55°C. The valve limits the flow of the circulation water in PHW systems with the increase of the temperature. When the temperature exceeds 55°C the valve closes the water flow and opens it when the water temperature in the circulation pipes decrease. The fixed temperature prevents unwanted temperature changes on the valve.

MEDIA

The valve is suitable for Potable Hot water (PHW).

TECHNICAL DATA

Pressure class: _____ PN 10
 Working pressure: _____ 1,0 MPa (10 bar)
 Close off pressure: _____ 600 kPa (6 bar)
 Operational dynamic differential pressure: _ max. 300 kPa (3 bar)
 Max. media temperature: _____ continuously 95°C
 _____ temporarily 100°C
 Min. media temperature: _____ 0°C
 Closing temperature accuracy: _____ ±2°C
 Connection: _____ External thread, ISO 228/1

Material

Valve housing and other metal parts with fluid contact:
 _____ DZR brass CW625N, resistant to dezincification

PED 2014/68/EU, article 4.3 / SI 2016 No. 1105 (UK)

Pressure Equipment in conformity with PED 2014/68/EU, article 4.3 and Pressure Equipment (Safety) Regulations 2016, (sound engineering practice). According to the directive/regulation the equipment shall not carry any CE or UKCA mark.

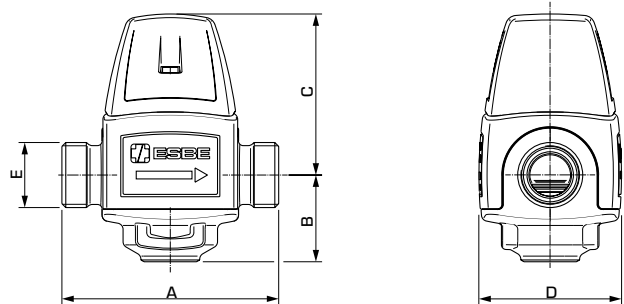

→ SERIES VTF322, EXTERNAL THREAD

Art. No.	Reference	Closing temperature	Kvs*	Connection	Dimension					Note	Weight [kg]
					E	A	B	C	D		
31220300	VTF322	55°C	1,8	G 3/4"	70	28	52	46	G 3/4"		0,45

* Kvs-value in m³/h at a pressure drop of 1 bar.

THERMOSTATIC FLOW LIMITATION VALVE SERIES VTF320

INSTALLATION EXAMPLES

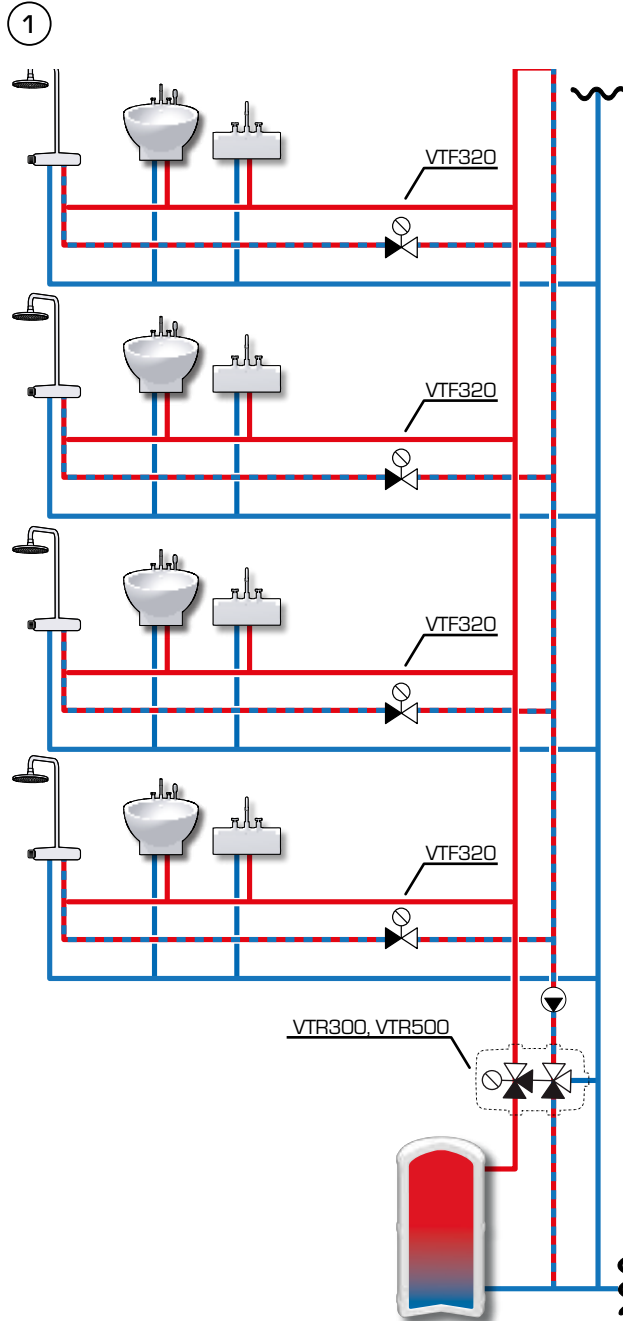

Potable hot water system with a tank and circulation, where VTR300/500 ensures the right PHW temperature and provides anti-scalding function and VTF320 provides the right temperature of circulation water in each zone by decreasing or shutting off the flow in case of exceeded PHW-C temperature above desired level, which results in low cost and energy usage.

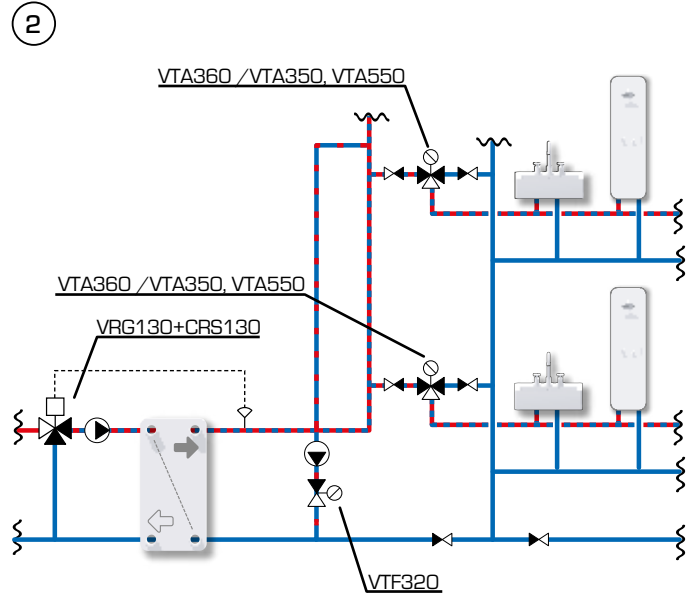

Indirect potable hot water system with plate heat exchanger and circulation, where mixing valve series VRG130 and controller series CRS130 ensure the right temperature of potable water controlling the primary heating water flow. The VTA350/550 Series ensure the right mixing temperature of the PHW for each zone and provide anti-scalding function. The VTF320 ensures the right temperature of the potable hot water circulation of the system by decreasing or shutting off the flow in case of exceeded PHW-C temperature above desired level, which results in low cost and energy usage.

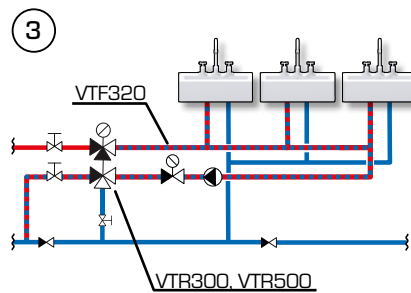

Potable hot water system with circulation, where VTR300/500 ensures the right PHW temperature and provides anti-scalding function and VTF320 provides the right temperature of circulation water of the system by decreasing or shutting off the flow in case of exceeded PHW-C temperature above desired level, which results in low cost and energy usage.

The shown applications are only examples of product use!
Before using the product in any application, the regional and national regulations need to be checked.